

Coleman Bias Regulator V1

1. General application.

- 1.1. The Bias Regulator is a low current (<1mA) shunt regulator, intended for grid-bias voltages in valve & tube amplifiers. It can also be used to bias Power MOSFETs, to provide a stabilised power supply voltage at higher current (with a few ohms of output impedance). It requires only one resistor change to program the bias voltage anywhere from -20V to -180V, and the output can be fine-tuned with the 25-turn trimmer.

2. Strong Overbias at Power On.

- 2.1. The arrival of Silicon Carbide 1200V rectifiers has at last given amplifier designers the option to use solid state rectifiers without the risk of noisy reverse-recovery current-pulses entering the signal circuits. But many designers are concerned about damage to the emission surface from the presence of the high voltage supply before the cathode/filament has warmed up. Although there is no available hard evidence for or against such mechanism, professional equipment makers of the past, and current-production tube makers have advised caution. So this bias regulator design avoids the risk - think of it as a version of the *Precautionary Principle* for electron tubes. At power-on, the regulator outputs a higher voltage - **equal to the input (supply) voltage** - for 20 seconds or so. This overbias reduces electric field around the emission surface to near zero, allowing a safe startup.

2.2. Scope-shot of startup output: Vertical (Y): 20V/division, and Horizontal (X): 5 seconds/div.:

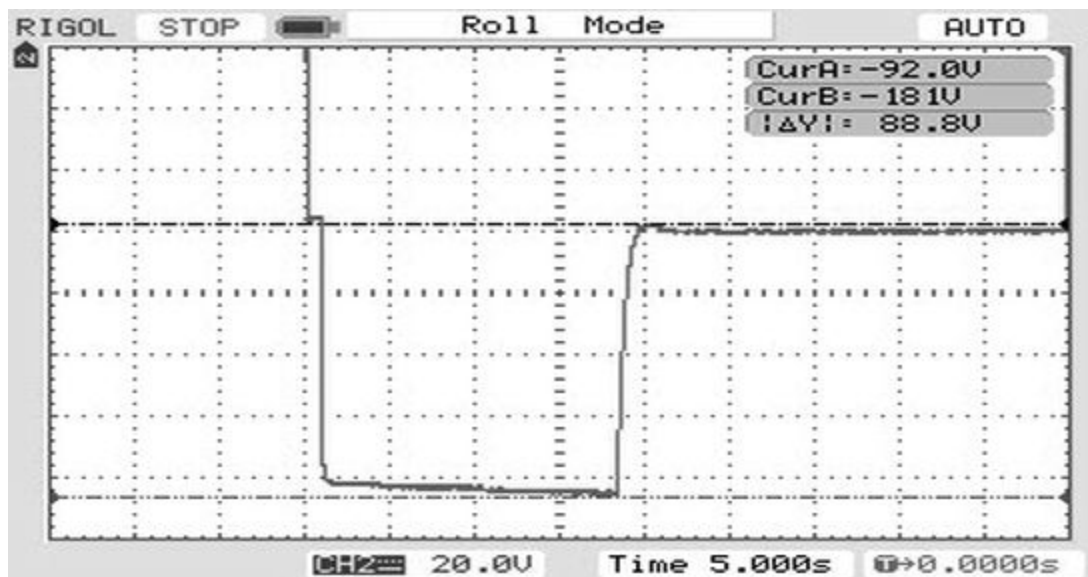

3. Application Schematic

3.1. The Regulator is designed to bias the grid of any valve/tube. The schematic shows how it is connected, and how to generate the raw dc supply voltage.

R1 & R2 for filtering and short-circuit protection.
Must be FLAMEPROOF type.

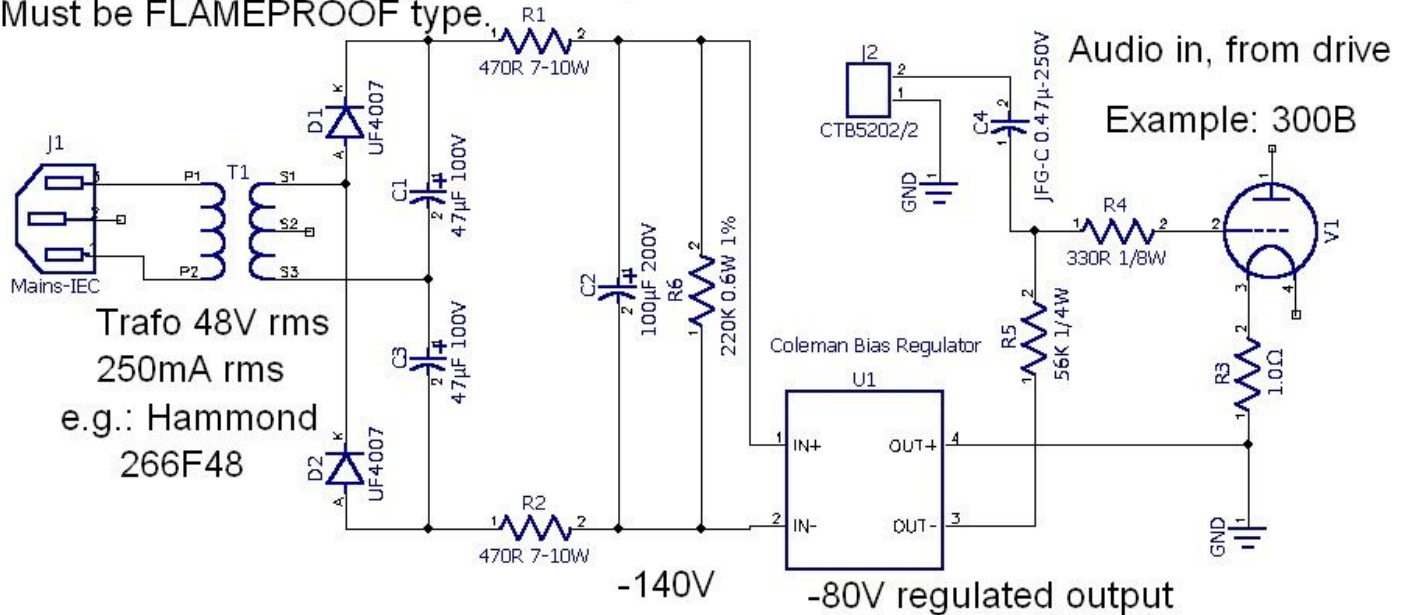

4. Requirements for the raw dc Supply

- 4.1. **Dc output.** The Regulator will work well so long as the input voltage is 15V or more above the output. The maximum input voltage is 200V, and the input to output voltage range is 15V to 160V. To take advantage of the startup bias (20-30 seconds with the output driven to the input voltage) please choose an input voltage that will bias your tube to 0mA, when the anode/plate voltage is applied.
- 4.2. **Supply current** is typically 5-6mA.
- 4.3. **Transformer.** The supply current is very low, so it's possible that a junk-box transformer will do, connected as a voltage doubler. The 48V rms Hammond 266F48 will generate 140V dc in the output of the circuit shown above.
- 4.4. **Winding Voltage vs. dc output:**

Transformer Secondary Voltage, Vrms	Raw DC voltage (circuit in §3.1)
55V rms	160V dc
48V rms	140V dc
40V rms	100Vdc
30V rms	72V dc

4.5. Components for Raw dc. Suggested parts - Where to buy:

Component	Type:	Mouser	Farnell Element14	RS
Transformer	48-50Vrms	546-266F48	1780873(40V)	504-066
D1, D2 Diode	Fairchild UF4007	512-UF4007	1467503	671-5470
C1, C3	47-100 μ F 100V	647-UVR2A101MPD	1834189	684-2128
C2	100 μ F 200V	80-ESH107M200AM7AA	9693220	867-6712
R1, R2	470 Ω	280-CR10-470-RC		206-1029

4.6. Dropper Resistors R1 & R2.

- 4.6.1. These filter the output, with C2. They also protect the rectifiers and trafo if there is a short circuit. For this reason they should be properly sized (7-10W wirewound) and they MUST be flameproof. Using two resistors (rather than 1K in the negative line) helps enforce wiring the output to C2 (avoid picking up recharge pulses) , and spreads heat wider, if there is a short circuit.

4.7. Output voltage

4.8. Choosing the output voltage.

- 4.8.1. Check the data sheet, and select the grid voltage for your operating point. If the individual tube has not been tested to check the grid voltage, please set the bias to be more negative than expected - you can trim it toward ground later, when you have measured the actual anode/plate current.
- 4.8.2. Effect of mains voltage. **Be sure to check that increases in mains voltage or B+ voltage do not cause the tube to overheat.** This can be a risk if the anode/plate supply is not regulated. Mains voltages can easily rise by 7%. If in doubt, bias colder (set voltage more negative), and take more measurements.
- 4.8.3. The output voltage is independent of the input voltage, and can be set by selecting one resistor R1 (and optionally adding R2 - a parallel 'trim' resistor). R2 allows you to choose voltages not easily available with single resistors, e.g. R1=R2 = 270K is equivalent to R1=135K, a value that may be difficult to obtain.
- 4.8.4. Trimmer RV1. Once the Regulator is built, the Trim-pot RV1 allows adjustment of the bias while the amplifier is running. You can monitor the cathode-current (with 1 or 10 Ω sense resistor in the cathode (R3 in the schematic), and adjust for optimum current.
- 4.8.5. Resistor types. A high quality metal film resistor should be used for R1 and R2. Rated 0.6W (or 0.5W) and 350V. Look for 1% or better tolerance, and 50ppm/ $^{\circ}$ C drift. The Vishay MBB0207 (through hole version) is the recommended type. **Do not use carbon film, metal oxide, or other types with poor temperature drift.**
- 4.8.6. R1 sets the output voltage, and R2 is in parallel to allow easier setting of the voltage. The range given in the table below is the adjustment range given by the trimmer pot, RV1.

Type:	R1:	Voltage: Pot Min. to Pot Max.	Type:	R1:	Voltage: Pot Min. to Pot Max.
GM70	270K	-100-120V	2A3	82.5K	-41-47V
GM70	220K	- 82-102V		75K	-39-45V
300Bxls, 50	200K	-79-97V		61.9K	-34-40V
300B, 50	160K	-64-79V	46	43K	-27-33V
	100K	-45-55V			

4.8.7.

5. Assembly.

- 5.1. **Solder and Cleaning.** Although the circuit handles only 200V maximum, we must take care not to create leakage paths across the PCB surface. Solder flux contamination is one risk. Old reels of solder with aggressive flux formulations will leave very leaky residues, and are best avoided. If you do use unknown flux types, be sure to clean the board after soldering, using PCB cleaner or a little Isopropyl Alcohol (IPA). Better still, use no-clean flux - and if there is much residue, clean it off. I recommend Stannol Kristall 400 solder. Tin-lead solder can be used, but lead-free solder with 3.5-4.0% silver gives stronger joints.

5.2. Top Side:



As shown in the photo, there is a silk-screen error in U1. Please mount U1 in reverse, as shown.

5.3. Bottom Side.

- 5.4. Mount the 47K resistor R(C1) across C1 pins.
- 5.5. **Correction of PCB error:** As shown, there is a cut in the PCB, and it should be already cut when you receive it. Add the supplied wire from Q1 (centre) to RV1(Centre):



47K across C1 Cut, already made Wire (supplied)

5.6. Dimensions (mm); Hole Positions, and Input/Output Terminals.

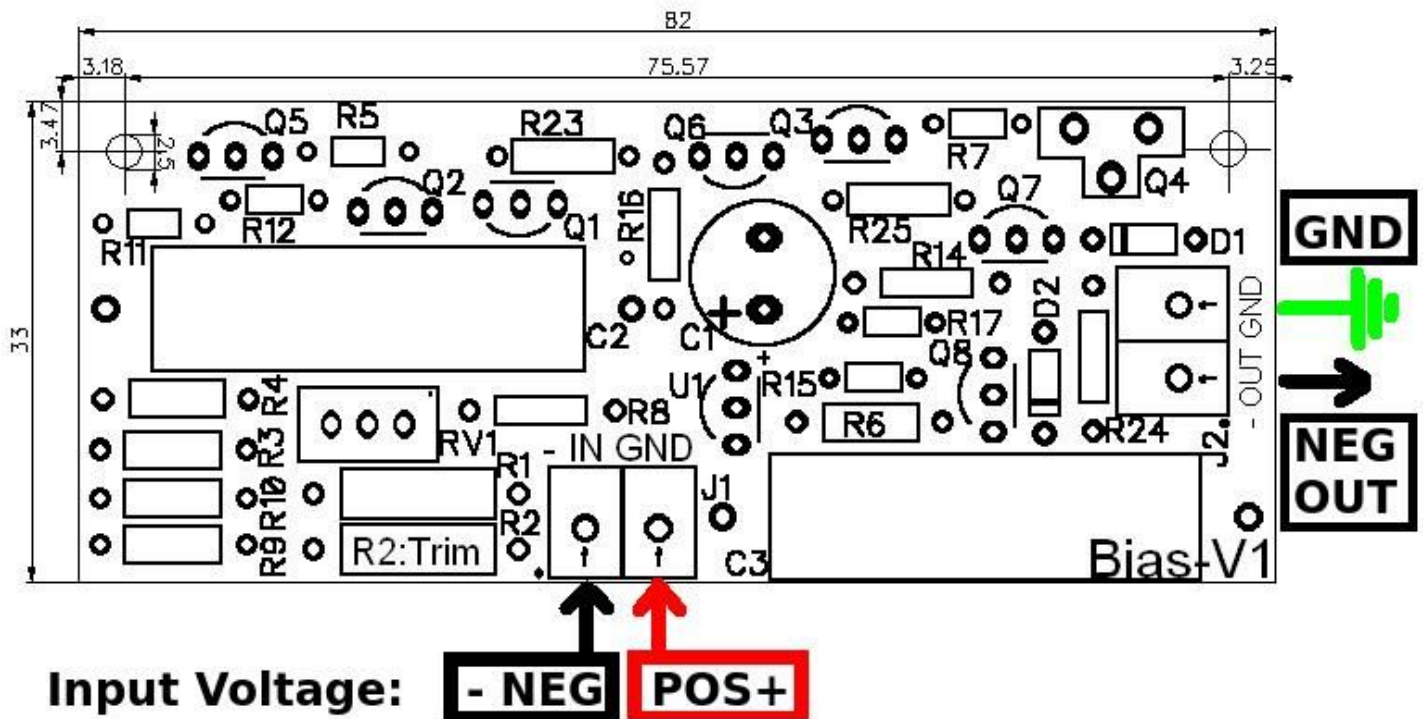

5.7. .